

WARNING: Always have Triumph approved parts, accessories and conversions fitted by a trained technician of an authorised Triumph dealer. The fitment of parts, accessories and conversions by a technician who is not of an authorised Triumph dealer may affect the handling, stability or other aspects of the motorcycle operation which may result in an accident causing injury or death.

WARNING: Throughout this operation, ensure that the motorcycle is stabilised and adequately supported to prevent the risk of injury from the motorcycle falling.

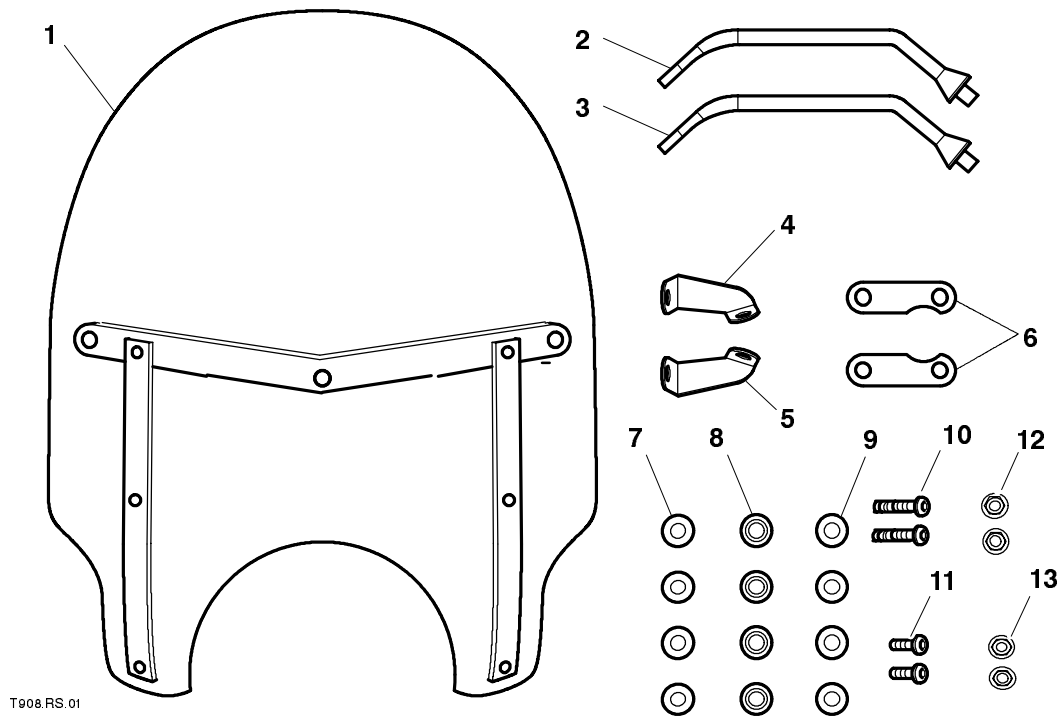

T908.RS.01

WARNING: This kit is designed for use solely on Triumph Bonneville motorcycles and should not be fitted to any other Triumph model or motorcycles of other manufacturers. Fitting this kit to any other Triumph model, or motorcycles from other manufacturers, may interfere with the rider and could affect the stability and handling of the motorcycle leading to an accident causing injury or death.

Parts Supplied

1. Screen	1	8. Rubber bushes	4
2. Upright (left-hand)	1	9. Finishing washers	4
3. Upright (right-hand)	1	10. Screws (long)	2
4. Lower bracket (left-hand)	1	11. Screws (short)	2
5. Lower bracket (right-hand)	1	12. Locknuts (large)	2
6. Top yoke brackets	2	13. Locknuts (small)	2
7. Foam washers	4		

Note: Not all components supplied will be needed for installation

Instructions part number A9900133 issue 1

© Triumph Designs 2000

1. Undo the two screws located under the rear of the seat and remove the seat.
2. Disconnect the battery, disconnecting the negative (-) lead first.
3. Slacken and remove the two screws securing the cable guide to the underside of the top yoke. Remove the guide (this will not be refitted).

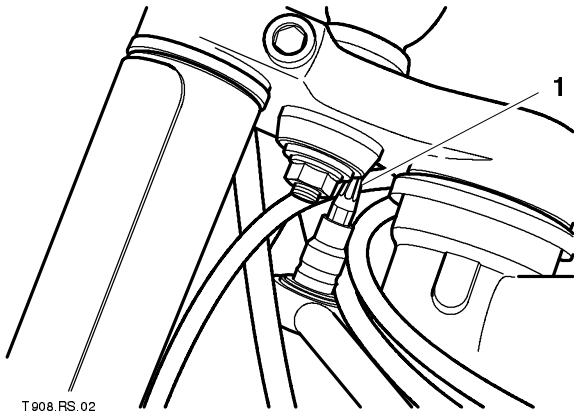

1. Cable guide screw location

4. Fit the top yoke brackets to the underside of the yoke, ensuring each bracket is fitted with its cutout at the rear and facing outwards (so it seats around the handlebar mounting). Secure the brackets in position with the cable guide screws, tightening them to **20 Nm**.

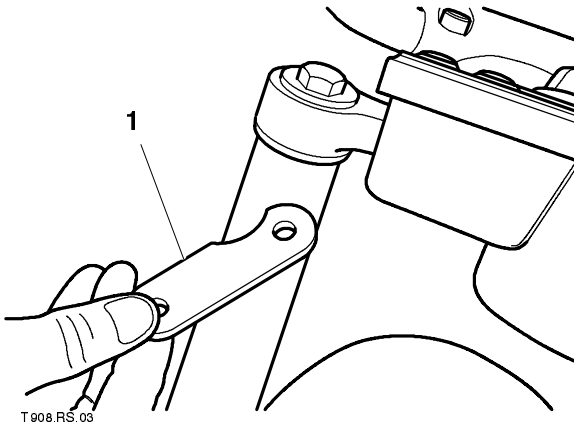

1. Top yoke bracket

5. Slacken and remove the headlight mounting bolts, taking care not to lose the mounting rubbers and spacers. Support the headlight.

6. Fit the lower mounting brackets correctly to the headlight left and right mounting bolts. Ensure the headlight mounting rubbers and spacers are correctly positioned then refit the mounting bolts, complete with brackets, tightening them lightly only.

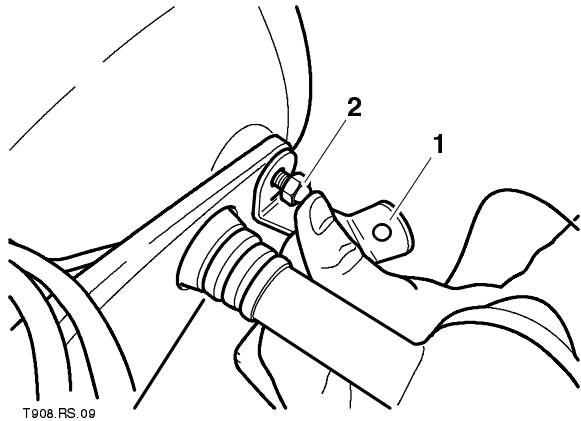

1. Lower bracket

2. Headlight mounting bolt

7. Fit the left-hand (marked LH) and right-hand (marked RH) uprights to the top yoke brackets, ensuring the clutch cable is correctly routed inside the left-hand upright as shown. Fit the large locknuts to the uprights, tightening them lightly only at this stage.

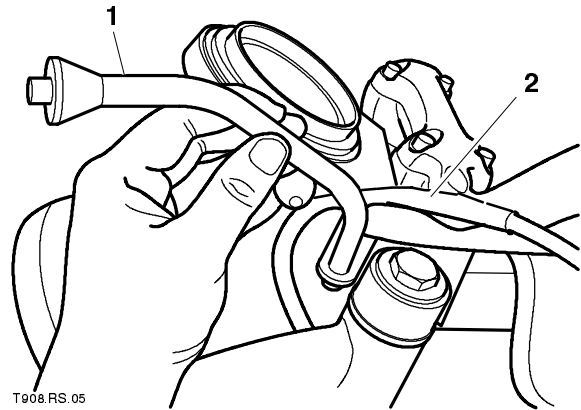

1. Upright

2. Clutch cable

- Fit a rubber bush to each upright, ensuring the bush shoulders abut the uprights.

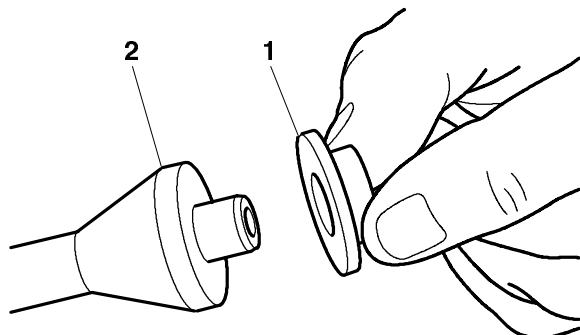

T908.RS.06

1. Rubber bush

2. Upright

- Manoeuvre the screen into position and locate it on the uprights.

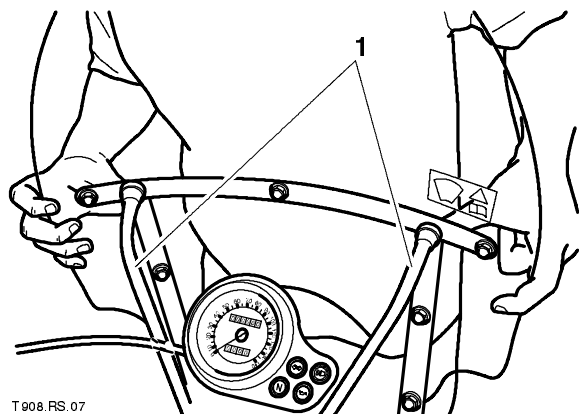

T908.RS.07

1. Uprights

- Position a foam washer between the screen and each lower bracket. Secure the screen to each bracket with a finishing washer and long screw. Fit a small locknut to each screw, tightening it lightly only at this stage.

- Secure the screen to each upright with a short screw and finishing washer. Tighten the screws to **9 Nm**.

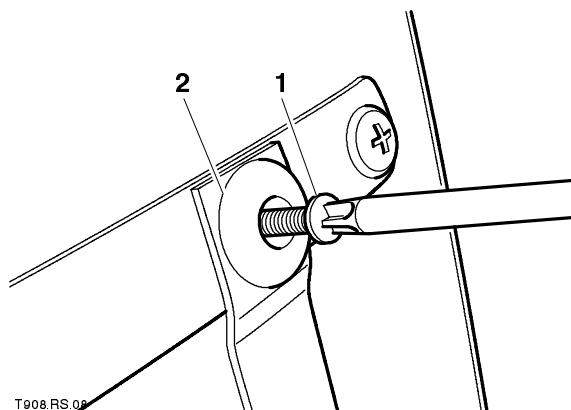

T908.RS.08

1. Finishing washer

2. Screw

- Tighten the upright locknuts to **20 Nm** and the screen lower mounting screws to **9 Nm**.

- Reconnect the battery, connecting the positive (+) terminal first. Refit the seat, tightening its screws to **10 Nm**.

- Adjust the headlight beam vertical aim then tighten the headlight bolts to **10 Nm**.



WARNING: Never attempt to clean or adjust the windscreen whilst riding the motorcycle. Removal of the rider's hands from the handlebars whilst riding the motorcycle will diminish the ability of the rider to maintain control of the motorcycle. Attempting to clean or adjust the windscreen whilst riding the motorcycle may result in loss of control of the motorcycle leading to an accident resulting in injury or death.



WARNING: After fitting the windscreen the motorcycle will exhibit new handling characteristics. Operate the motorcycle in a safe area free from traffic to gain familiarity with any new handling characteristics. Operation of the motorcycle when not familiar with any new handling characteristics may result in an accident causing injury or death.



WARNING: If, after fitment of the windscreen, there is any doubt as to any aspect of the performance of the motorcycle, contact an authorised Triumph dealer and do not ride the motorcycle until the authorised Triumph dealer has declared it fit for use. Riding a motorcycle when there is any doubt as to any aspect of the performance of the motorcycle may result in loss of control of the motorcycle leading to an accident causing injury or death.



WARNING: The windscreen is not a substitute for a helmet or eye protection. When riding a motorcycle both rider and passenger must always wear a crash helmet, eye protection, gloves and trousers (close fitting around the knee and ankle). Although full protection is not possible, wearing correct protective clothing can reduce the risk of injury when riding. Failure to wear correct protective clothing when riding a motorcycle may result in an accident causing injury or death.



WARNING: Windscreens are designed to provide wind protection and increased riding comfort. They are not designed to provide protection in the event of a collision with another vehicle, the road, birds or any other object. When riding a motorcycle both rider and passenger must always wear a crash helmet, eye protection, gloves and trousers (close fitting around the knee and ankle). Although full protection is not possible, wearing correct protective clothing can reduce the risk of injury when riding. Failure to wear the correct protective clothing when riding a motorcycle may result in an accident causing injury or death.



CAUTION: Chemicals such as battery electrolyte, solvents and brake fluid will damage the windscreen. Never allow such chemicals to contact the windscreen.